



SS-Series L-Bar Sealers
Model: SS-1622MK

Distributed By:

Version 1.0
Last Updated: 10/15/19

SS-1622MK Sealer Service Manual

IMPORTANT – PLEASE READ THIS CAREFULLY

The development of a good safety program, that is rigidly enforced, is absolutely imperative when involved in the operation of industrial equipment. Our machinery is well designed and includes extremely important safety features. The part you the user play through proper installation and maintenance procedures is of far greater significance than our designs. Only properly trained individuals following rigidly enforced safety rules, as recommended by A.N.S.I. and O.S.H.A., should be allowed to operate these machines.

SS-1622MK Sealer Service Manual

TABLE OF CONTENTS

Preface

Unpacking	4-7
Warranty Notice	8
Warranty	9-10
Warranty Exceptions	11
Warnings	12-14

Sealer Section

Description and Specifications	15
Installation and Basic Set-Up	16-22
Film Threading Diagram	23
Sequence of Operation	24-26
Compensator Adjustment	27-28
Troubleshooting	29-46
No Heat to "Micro Knife" Band Ribbon	29-34
Unbalanced Heat from Front and Side	35-36
Weak Seals/Poor Cut Off	37-38
Conveyor Will Not Run	39-41
Magnetic Hold Down	42-44
Excessive Film Drag	45
Excessive Film Winding	46
Maintenance	47-71
Electrical Schematic	72
Electrical Panel Diagram	73
Parts Nomenclature	74
Replacement Parts List	75-78
Spare Parts List	79

SS-1622MK Sealer Service Manual

UNPACKING**THOROUXCELY INSPECT EQUIPMENT UPON ARRIVAL.**

If goods are received short or in a damaged condition, it is important that you notify the carrier's driver **before he leaves your company** and **insist** on a notation of the loss or damage across the face of the freight bill. Unless this is done, no claim can be enforced against the transportation company.

If concealed loss or damage is discovered, notify the carrier at once and insist on an inspection. This is absolutely necessary! A concealed damage report must be made no later than ten (5) days from the date the shipment was delivered. Unless you do this, the carrier will not consider any claim for loss or damage. The carrier's agent will then make an inspection and grant a concealed damage notation. If you give the transportation company a clear receipt for the goods that have been damaged or lost in transit, you do so at your own risk and expense.

All claims must be filed within 5 days of delivery date or carrier will not accept them.

Sealer Sales is willing to assist in every possible manner to collect claims for loss or damage; however, this does not hold Sealer Sales responsible for collection on claims or replacement of material.

SS-1622MK Sealer Service Manual

Your new L-Bar Sealer comes bolted to a pallet and has a tri-walled corrugated box strapped to the pallet to protect it.



1. If your machine does not arrive in this condition, **write on shipping paperwork that outside of box is damaged. Concealed damage may have occurred.**



2. Remove stretch film and Poly Bag covering machine.

SS-1622MK Sealer Service Manual



3. Remove film rack from under L'Sealer.

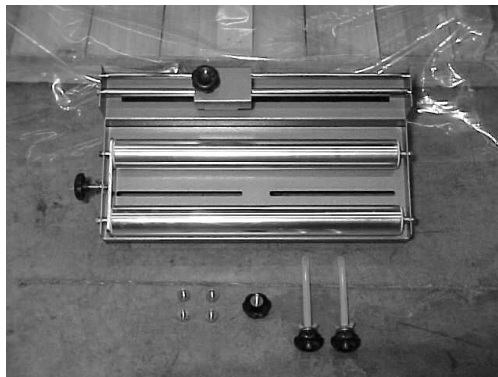

4. Check film rack. You should have
 - (a) Film Rack
 - (b) (4) mounting bolts
 - (c) (1) adjustable knob
 - (d) (2) film roll guides

SS-1622MK Sealer Service Manual

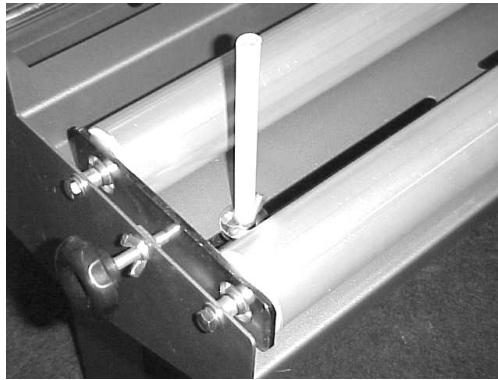

5. Mount film rack roll guides as shown.



6. Remove bolts holding L-Bar Sealer to pallet using 13 mm wrench.
7. Place forks of forklift under center of lower support bar of L-Bar Sealer frame and lift off pallet.
2. Place in desired location and use locking casters to set in place.

SS-1622MK Sealer Service Manual

IMPORTANT WARRANTY NOTICES**OPERATING AND MAINTENANCE MANUAL**

The operating and maintenance manual has been carefully prepared to provide the user with all the information needed to properly install, operate, and maintain your Preferred Packaging equipment.

Please read this manual carefully and refer to it for information on the care and use of your equipment. It is recommended that additional copies be ordered for use by production, maintenance, and supervisory personnel. Although the design of this equipment incorporates safeguards to protect personnel, care should be used in operating, adjusting, and servicing.

Attention is directed to the warranty which accompanies all your equipment. The terms and conditions of this warranty apply only to unmodified units. Any unauthorized modifications to the equipment automatically voids this warranty.

SS-1622MK Sealer Service Manual

Sealer Sales

WARRANTY

Sealer Sales, Inc. warrants each new product manufactured to be free from defects in material and workmanship for a period of (1) year from date of shipment by Sealer Sales.

This warranty is not transferable with any subsequent resale.

Defective parts under warranty must be returned to Sealer Sales freight prepaid. Sealer Sales's sole obligation and purchaser's sole remedy in the event of a warranty dispute shall be, at Sealer Sales's option, to repair or replace the part in question. Labor incurred in removing or installing the defective part is not covered by this warranty. Prior to returning any parts for any reason, contact Sealer Sales for a Return Authorization Number. This number must accompany all returns.

This warranty shall not apply if equipment has been tampered with, misused, improperly installed, altered, or has received damage due to abuse, carelessness, accident or failure to follow recommended regular maintenance procedures or has been serviced by someone other than a duly authorized factory representative without the express written consent of Sealer Sales, Inc.

This warranty is in lieu of all other warranties, expressed or implied, including but not limited to warranties of merchantability and fitness for a particular purpose, non-infringement or any other matter.

SS-1622MK Sealer Service Manual

Sealer Sales shall have no liability to any person for direct, indirect, incidental or consequential damages or delay resulting from any defect negligence, or tort and customer hereby waives for itself any and all claims for punitive damages and all claims of negligence of strict liability or both. In no event shall our liability exceed the purchase price of the product which was actually paid.

Sealer Sales reserves the right to make changes, additions, or improvements to our products with no obligation to make such changes in any previously shipped product covered by this warranty.

Sealer Sales shall not be held liable for any damages arising out of or in connection with the operation of the equipment should customer or its agent fail to maintain equipment in safe operating condition. This warranty shall become unenforceable if and to the extent the customer or its agents remove, disconnect, or otherwise render useless any safety device and or parts designed or affixed by us or fails to maintain and service equipment in a manner as advised.

Sealer Sales provides a two year warranty on parts, excluding shipping or freight costs for replacement parts. All warranty parts are shipped F.O.B. Rancho Cucamonga, California.

SS-1622MK Sealer Service Manual

WARRANTY EXCEPTIONS

The following parts are an exception to the general warranty list on page 9. Each part listed below shall carry a 30-day warranty unless designated otherwise.

SS-1622MK Sealer Parts

1. Conveyor Belt
2. Fuses

The following sealer parts are considered to be consumable and not under warranty:

1. Silicone Sponge
2. Teflon Tapes
3. Nylon Sleeves

SS-1622MK Sealer Service Manual

WARNINGS

Every effort has been taken to ensure your safety while operating this machine; however, there still remain certain risks. Do not allow this machine to be operated before informing all personnel of the following warnings.

WARNING.....

Do not tamper with the electrical wiring. Only use a licensed electrician for maintenance. Always disconnect the electrical power before attempting any maintenance to all electrical and/or moving parts.

WARNING.....

In order to prevent injury to personnel and/or machinery DO NOT INCREASE SETTINGS OR RATINGS ON EITHER ELECTRICAL OR MECHANICAL OVERLOAD SAFETY DEVICES.

WARNING.....

KEEP HANDS AWAY FROM MOVING CONVEYORS AND ASSEMBLIES. Conveyor belts that have become worn or frayed are capable of being hazardous. They should be replaced promptly.

WARNING.....

NEVER OPERATE THIS OR ANY MOVING EQUIPMENT WITHOUT ALL COVERS AND GUARDS IN PLACE. The internal mechanism of most packaging machinery contains numerous shear, pinch, and inrunning nip points, many of which are capable of causing severe injury and/or permanent disfigurement.

SS-1622MK Sealer Service Manual

WARNING.....

To minimize the potential for personnel injury, always be sure that machine operators and others working on the machinery are properly trained in the correct usage of the equipment and properly instructed regarding the safety procedures for operation.

WARNING.....

Heat sealing arms and sealing jaws on packaging machinery can become very warm after a period of use. KEEP HANDS AWAY WHILE IN OPERATION AND USE CAUTION IF THE MACHINE HAS BEEN RUNNING RECENTLY.

WARNING.....

ANY MODIFICATIONS TO EITHER THE ELECTRICAL CIRCUITRY OR THE MECHANICAL ASSEMBLIES OF THE MACHINERY WILL VOID ANY WARRANTIES ASSOCIATED WITH THIS EQUIPMENT. Such modifications may introduce hazards that would not otherwise be associated with this machinery. Sealer Sales will not be responsible for any consequences resulting from such unauthorized modifications.

WARNING.....

The use of certain types of plastic films in sealing and/or shrinking equipment may result in the release of HAZARDOUS FUMES due to the degradation of the film at high temperatures. Before using any plastic film in this equipment, the manufacturer or supplier of the film should be contacted for specific information concerning the potential release of hazardous fumes. ADEQUATE VENTILATION MUST BE PROVIDED AT ALL TIMES.

SS-1622MK Sealer Service Manual

WARNING.....

It is important that the machine operator turn off the Main Power Switch when he/she has finished operating the unit.

SS-1622MK Sealer Service Manual

**DESCRIPTION AND SPECIFICATIONS OF
MODEL SS-1622MK SEALER**

DESCRIPTION

The purpose of a SS-1622MK Sealer is for medium to high volume packaging requiring excellent seals and minimal maintenance. It features **"micro knife technology"** for sealing of films. This model incorporates an electromagnetic hold-down system, allowing the operator to load another package while the preceding package is being sealed. This system provides consistent seals. In addition, a package take-away conveyor increases production speed by automatically discharging product into the tunnel.

SPECIFICATIONS

Model:	SS-1622MK
Seal Area:	Width: 16"
	Length:
Machine Size:	22" Width:
	27" Length:
	63" Height:
Volts:	43" 220
Amperage:	15
Weight:	300 lbs.

SS-1622MK Sealer Service Manual

INSTALLATION AND BASIC SET-UP**IMPORTANT**

Read this manual carefully, and make it available to everyone connected with the supervision, maintenance, or production of this machine. Additional copies are available at your request. (Contact your distributor for this information.) Be very careful when operating, adjusting, or servicing this equipment. If in doubt, stop and obtain qualified help before proceeding.

INSTALLATION OF SS-1622MK SEALER

Place the L-Bar Sealer in the desired location with the required electrical power source available. (See power requirements.) Make certain that proper electrical wiring is provided to guard against low voltage. If the voltage is too low, the equipment will not function properly.

Finding the proper location is a most important function of the initial set-up. One must take several factors into consideration:

1. Adequate power source.
2. Relationship to source of product.
3. Relationship to L'Sealer.
4. Relationship to any conveyors necessary to remove finished product.
5. Convenience of operator.

An electrician should install a plug on the end of the main power cord. If there is any doubt, get qualified assistance to do the initial installation. **Do not take any chances!**

SS-1622MK Sealer Service Manual

Do not attempt to install, adjust, or operate this machine without first reading the contents of this manual. Although the design of the equipment incorporates safeguards to protect operating and maintenance personnel, care should be used in operating, adjusting, and servicing.

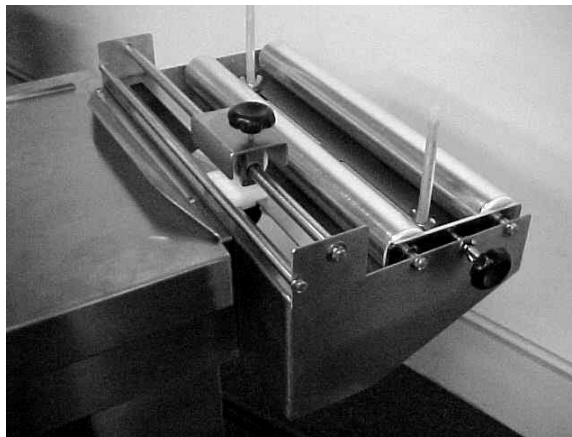
INSTALLING FILM RACK

IMPORTANT: Remove film rack from under sealer and install at the end of the sealer on the right hand side with the four bolts and center knob provided. Mounting holes are slotted for adjustment, set film rack flush with back side of the machine frame.

SS-1622MK Sealer Service Manual

MOUNTING FILM

Select the proper width of center-fold film for the item being packaged, allowing for width and height of package. With the package properly positioned within the film in the sealing area, allow sufficient film to overlap the sealing bars so that a seal may readily be made without any possibility of open areas due to insufficient film.

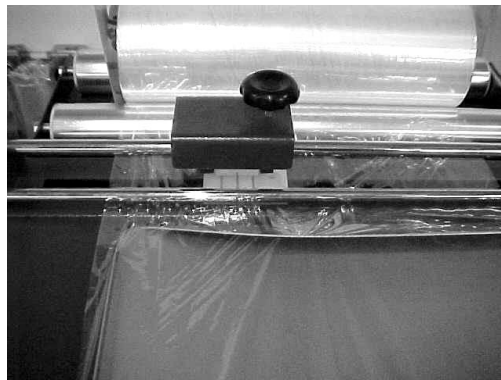

Place film roll on cradle mount film rack. The center-fold is to be placed away from the operator, toward the rear of the machine. Position film roll on rack and tighten film guide nuts to hold film roll in position.

Thread film through the Pin Perforator. Note that the perforator wheel turns freely and is not binding.

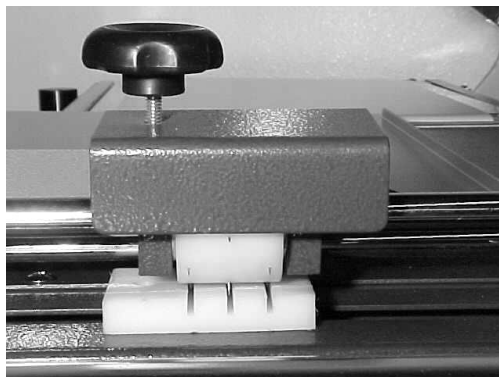

SS-1622MK Sealer Service Manual

Once threaded, separate film top from bottom and insert product tray between. Make sure that the center-fold of film is placed at the rear of the product tray. This allows the operator to insert product between the layers of film on the product tray and to prepare to move product and film into the sealing area. When threading film, make sure to pull more than sufficient film through the rollers, across the product tray, and into the sealing area to ensure sufficient film to begin operation.

Place product against rear of film separator tray. Then move product into seal area. Be sure to leave the bag loose around the product when making the seal. This helps eliminate the seals from blowing out in the shrink tunnel. This completes threading and/or mounting film.

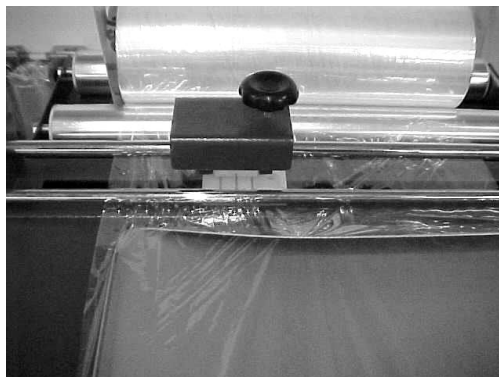
PIN PERFORATOR

Located between the lower idler rollers, the pin perforator creates holes for air escape as the operator pulls on the film. This allows the air to escape as the package travels through the tunnel.

The pin perforator is adjustable and must be properly placed in conjunction with the width of the desired package. The positioning

SS-1622MK Sealer Service Manual

should always be re-evaluated when setting the machine for different size product or different size film. Adjustments may be made with the adjustment knob attached to the bottom of the film rack.

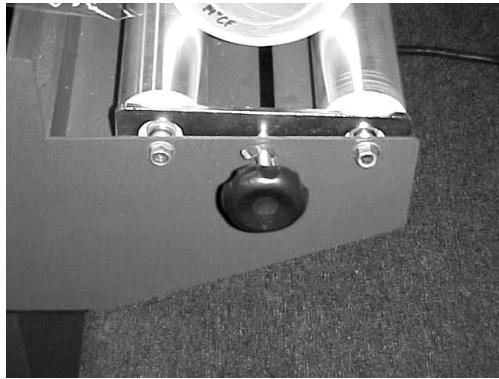
FILM BRAKE

The film brake is located on the operator side of the film cradle. It serves to create tension on the dispensing film, in order to prevent over-run and/or slack. From time to time, the operator should re-evaluate its setting to ensure proper tension.

PRODUCT TRAY

SS-1622MK Sealer Service Manual

The product tray is an adjustable metal platform used to separate film and to insert product between top and bottom layers of film.

The tray is adjustable to achieve proper depth, equal to the depth of the package, allowing product to be placed exactly in the center fold of the film each time. A locking wing screw allows you to set tray position.

LOCKING WING SCREW

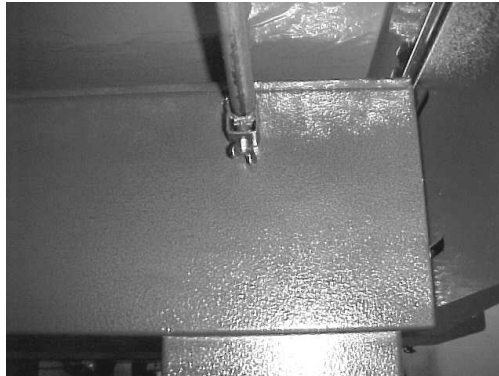

Once the product is placed in the desired location, tighten the wing screw under the loading tray to lock tray in position.

Power Discharge Conveyor



SS-1622MK Sealer Service Manual

Lower Power Discharge Conveyor using the crank wheel located underneath the Power Discharge Conveyor. The Conveyor should be set so the package height is centered to the seal pad. In essence, $\frac{1}{2}$ of the package is above the seal pad and the other $\frac{1}{2}$ of the package is below the seal pad. This will place the seal in the center of your package and help release any film tension that may occur.

SS-1622MK Sealer Service Manual

FILM THREADING DIAGRAM

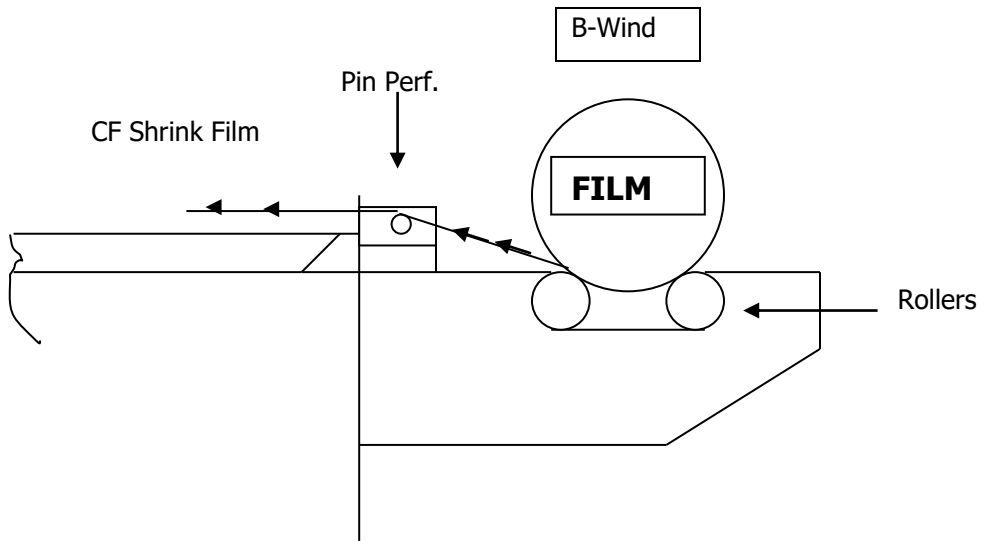

SS-1622MK Sealer Service Manual

SEQUENCE OF OPERATION

- A. Product is placed on the film separator tray.
- B. The product tray functions as a means to separate the film, allowing placement of product between upper and lower portions of the film.
- C. Move product into seal head area by pushing the product to the left.
- D. As the seal head is lowered toward the bottom seal pad, the cycle switch is activated which initiates the "micro knife" Band Ribbon, magnet time and conveyor time. The timers are located in the front of the machine and can be adjusted from 0 to 6 seconds.
- E. Take-away Conveyor Unit – Once the seal is completed, the seal head automatically releases and the take-away conveyor begins to run. It is adjustable from one (1) to six (6) seconds. The timer is located on the front of the machine.

NOTE: If too much tension is on the film while the bag is being made, the seals will, more than likely, be weak or will "blow out" in the seal area while passing through the shrink tunnel. Make sure to relax the film tension prior to sealing.

SS-1622MK Sealer Service Manual

SEQUENCE OF OPERATION

3. After setting the Band Ribbon compensator for the film type in use (see page 27 for instructions), proceed as follows:



4. With film threaded, (see instructions for mounting film) place right hand on package and slide product into the upper left hand corner of the film (i.e. corner formed by folded rear edge of film and previously sealed left edge of film), pushing the package up against the 1/2" high package stop at rear of product loading tray.



- B. Place **right hand** under top sheet of film and on front right corner of product. Place **left hand** on tail of both sheets of film. Now push the package with right hand

SS-1622MK Sealer Service Manual

and pull the film with left hand moving package and film into lower right corner of seal area. Allow from 1/2" to 1" of extra film around package. This will allow some slack film between the package and the sealing bars, reducing film tension.



- C. Press sealing handle down. **IMMEDIATELY** release pressure. The sealing head will remain down for the duration of the time set on the seal timer.



- D. The operator may then load the next package onto the product tray, thus speeding up the sealing operation.

SS-1622MK Sealer Service Manual**COMPENSATOR ADJUSTMENT**

Because of the importance of the adjustment of the Band Ribbon compensator to the successful operation of the sealer, the following explanation of its operation is given.

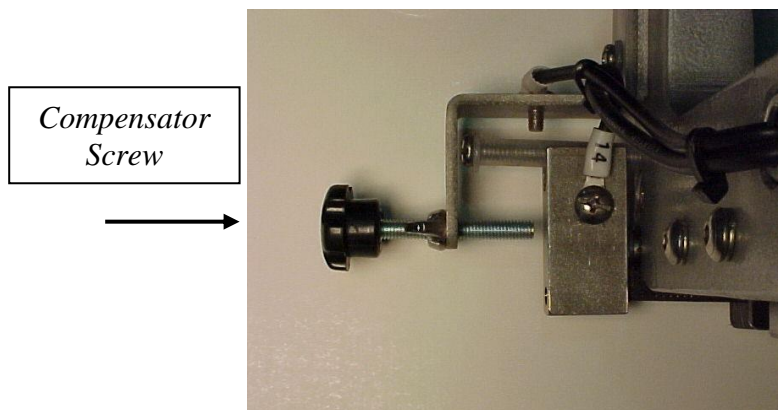

The front stainless steel compensator is used to adjust the Band Ribbon temperature. As the seal head is lowered against the bottom seal pad, a pulse switch is activated at the rear of the seal bar supplying voltage to heat the Band Ribbon. As the Band Ribbon heats up, the stainless steel compensator is spring-loaded and expands as the Band continues to heat. When the compensator finally expands to the point that it touches the threaded screw, the circuit is completed and the supply voltage is turned off. The simple principle of this device is to compensate for the residual heat that builds up in the Band Ribbon. As you operate the L-Bar Sealer faster and faster, the actual amount of heat from the Band Ribbon stays constant, reducing the amount of heat transferred to the Teflon tape or seal sponge.

NOTE: The farther away you set the threaded compensator screw from the compensator, the hotter the Band Ribbon will become. A good starting point is to allow a gap of $\frac{1}{4}$ ". Thicker film such as 100GA Polyolefin might require a slightly larger gap.

SS-1622MK Sealer Service Manual

TROUBLESHOOTING

The following guidelines are provided to aid in determining the source of any operation difficulties that may develop. In performing the tests and checks which follow, carefully inspect for any loose components, broken or loose wires, poor electrical connections, etc., while testing the various switches, controls, relays, transformers, etc. For checking electrical problems, use a voltage meter.

Note: While troubleshooting use caution to avoid danger of electrical shock. When power is not required for checking for the presence or value of voltages used, always have it disconnected.

DISCONNECT ALL POWER BEFORE MAKING ANY REPAIRS.

REFER TO ELECTRICAL BOARD LAYOUT AND ELECTRICAL SCHEMATIC FOR LOCATION OF ELECTRICAL COMPONENTS

NO HEAT TO BAND RIBBON

5. Check that the sealer is plugged in and that power is present at the socket. Make sure the power switch is in the **ON** position.

SS-1622MK Sealer Service Manual



2. Make sure timer is **not** set on zero (0) on time dial.

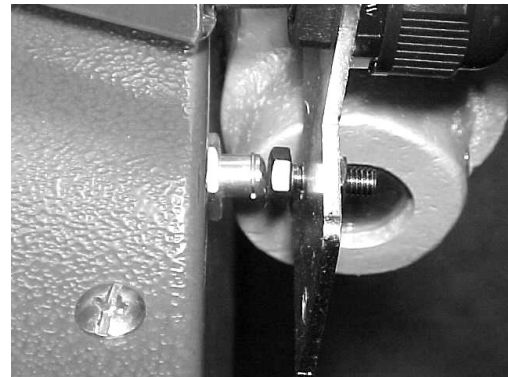
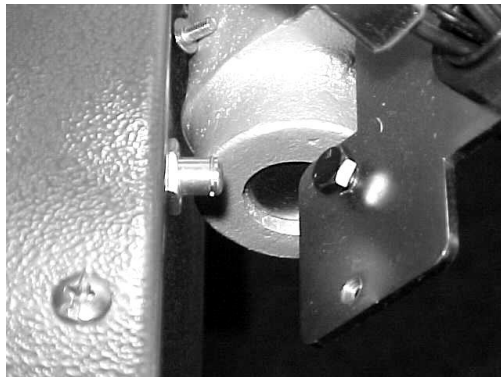

3. **Check micro knife pulse switch adjustment.**
 - (a) Make sure switch is being activated when the seal bar is within $\frac{1}{4}$ " of contact with seal pad.
 - (b) Press switch by hand. If no click is heard, replace switch.

SS-1622MK Sealer Service Manual

F6 – 2 AMP
F5 – 3 AMP
F4 – 2 AMP
F3 – 15 AMP

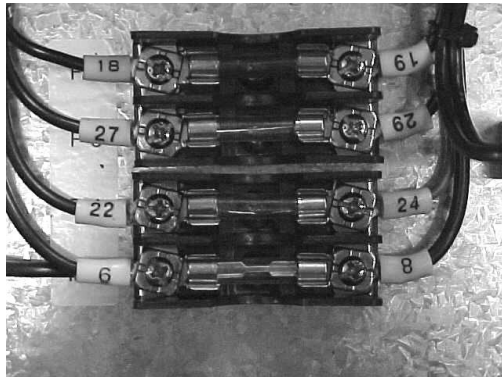

F1 – L1 --15AMP
F2 – L2 -- 15 AMP



4. Check all fuses.

SS-1622MK Sealer Service Manual

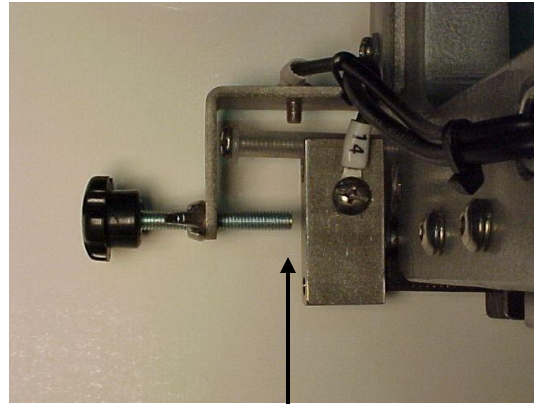

GAP 1/8" to 1/4"

5. Check micro knife compensator setting. You should always have a gap of at least 1/8" to 1/4" between the compensator and the adjustment screw. If the compensator screw is touching the compensator the micro knife will not heat up.

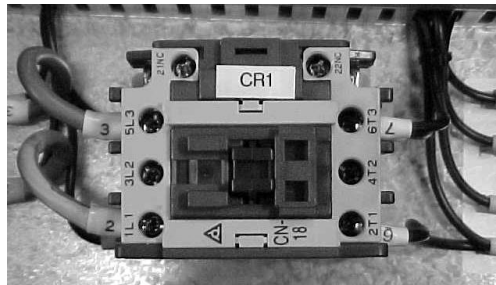

6. Check to see if CR1 contactor is pulled in at all times when Main Switch is in the ON position.

SS-1622MK Sealer Service Manual

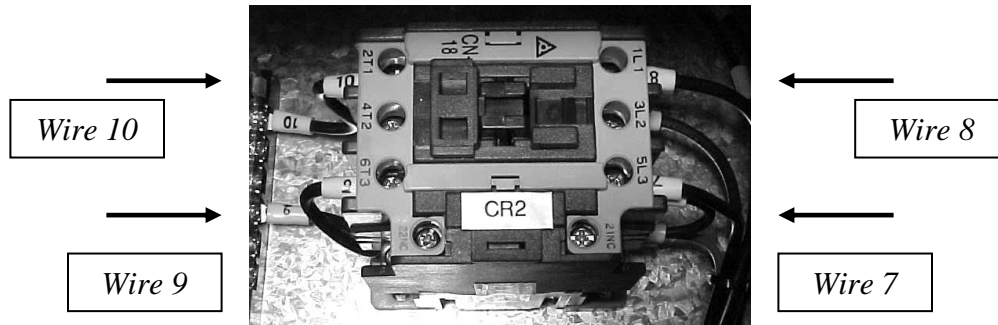

7. Check for operation of contactor – CR2.
 - (a) Check for 220 power on wires 7 and 8. When CR2 is pulled in, you should have 220 present on wires 9 and 10.
 - (b) Manually engage contactor and check for continuity on each leg. If required, clean or replace contact points or replace contactor.

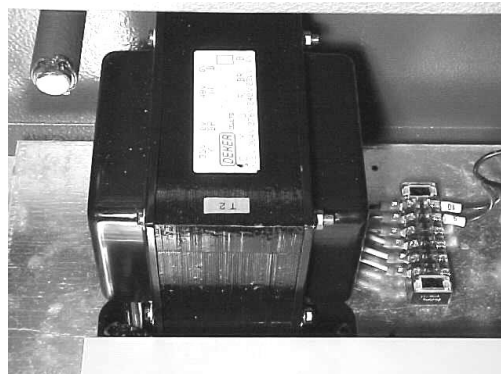

8. Check for voltage present at both primary and secondary of transformer T2 as per values shown in the voltage specifications.

SS-1622MK Sealer Service Manual

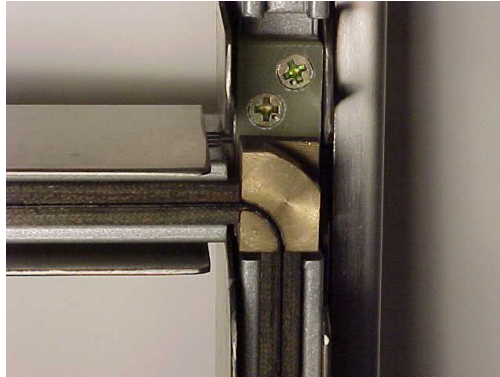

9. Check for broken band ribbon inside or outside the corner block.

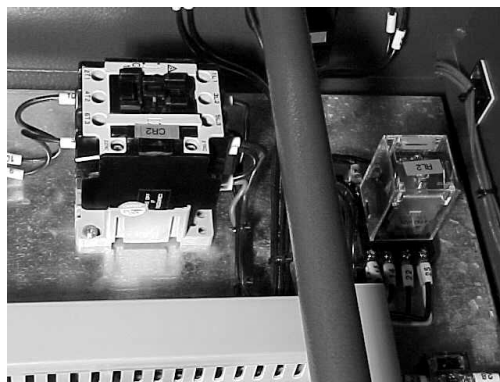

← RL2

10. Check RL2 relay to make sure it is secure in the socket.

SS-1622MK Sealer Service Manual

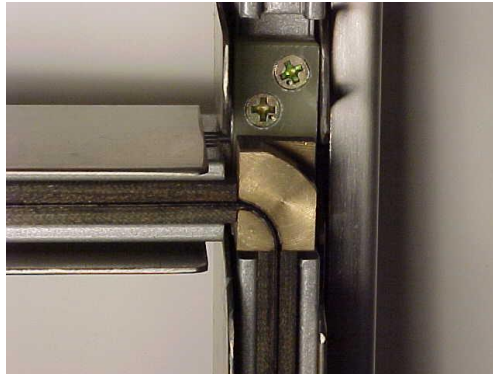
**UNBALANCED HEAT FROM FRONT
AND SIDE MICRO KNIFE BAND RIBBON**

1. Check corner block, make sure Teflon insulation piece covering micro knife band ribbon described on page 27 is securely in place. **If Teflon insulation is missing or worn out the band ribbon will ground against corner block not allowing heat to transfer in the corner.**

SS-1622MK Sealer Service Manual

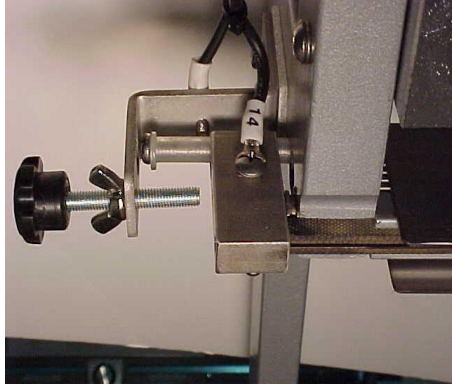

Check Wires 14 and 26

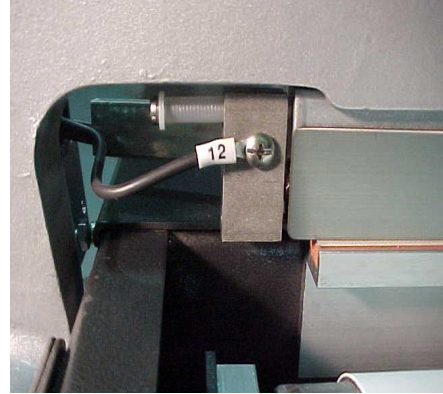

Check Wires 12 and 13

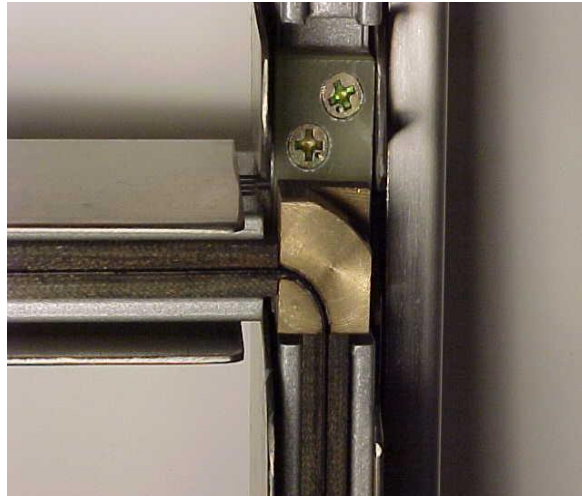

2. Check for poor connection in corner block.

TROUBLESHOOTING—UNBALANCED HEAT FROM SEALING WIRES

SS-1622MK Sealer Service Manual

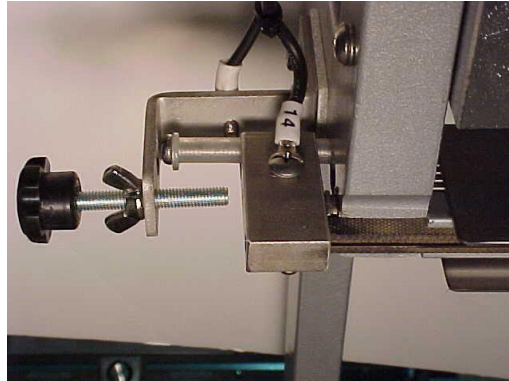
WEAK SEALS AND/OR POOR FILM CUT-OFF

1. Improper setting of micro knife compensator. Refer to page 27 for proper adjustment.



2. Improper operating technique. Too much film tension, make sure film is relaxed prior to sealing.
3. Check band ribbon to see if cleaning or replacement is necessary.

SS-1622MK Sealer Service Manual

4. Burned Teflon tapes $\frac{1}{2}$ " or $\frac{3}{4}$ " replace. If Teflon tapes become burned or worn, weak seal may occur. See page 54 for Replacement Instructions.
5. Wavy silicone rubber sealing pad. Replace. (See instructions on page 55.)
6. Seal pad pressure incorrect. (See page 56.)
7. Hold-down pressure uneven or incorrect on magnets. (See page 59 for instructions.)

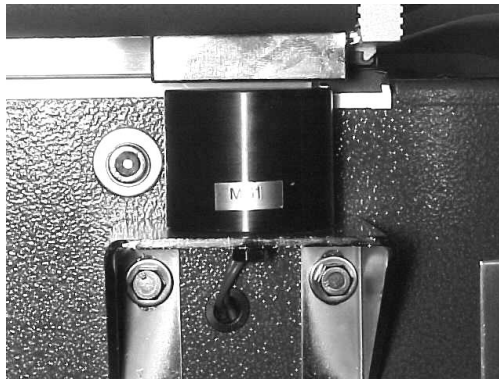

8. When seal bar is lowered, the gap between the lower magnet and the upper magnet clamp should be $\frac{1}{8}$ ".

SS-1622MK Sealer Service Manual

CONVEYOR – WILL NOT RUN

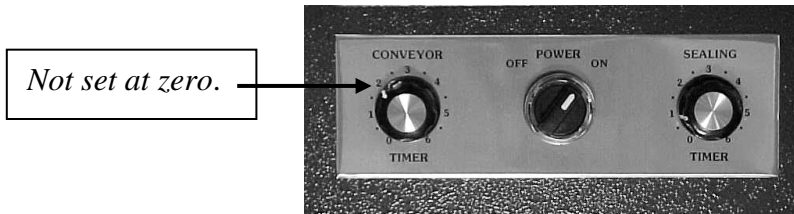

1. **Check conveyor timer.** Make sure it is **not** set at zero.

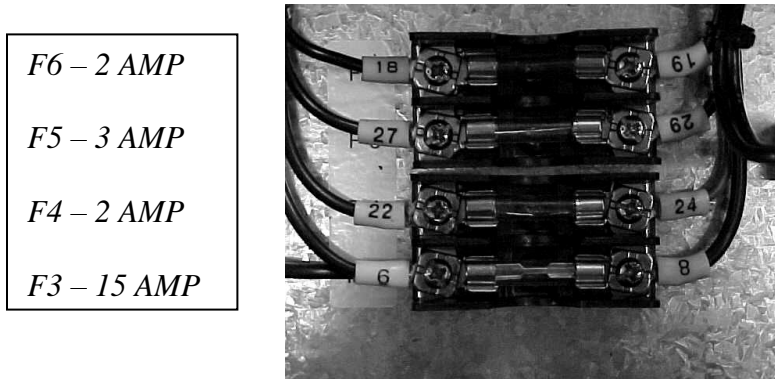

2. **Check fuse F-6, 2 AMP, wire 18 and 19.**

SS-1622MK Sealer Service Manual

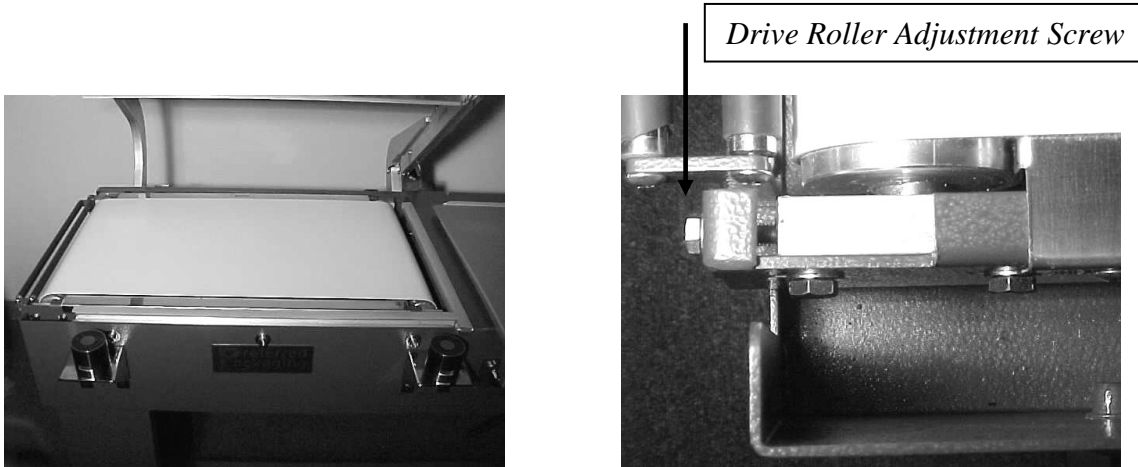

3. **Check conveyor belt** and make sure it is not adjusted too tightly. Adjust conveyor belt using Drive Roller Adjustment Screw.



4. Check that conveyor motor sprocket set screws are not loose on shaft.
5. Check that conveyor chain is not jammed or broken.
6. Make sure wires number 19, 20 and 7 are connected to the conveyor motor.

SS-1622MK Sealer Service Manual

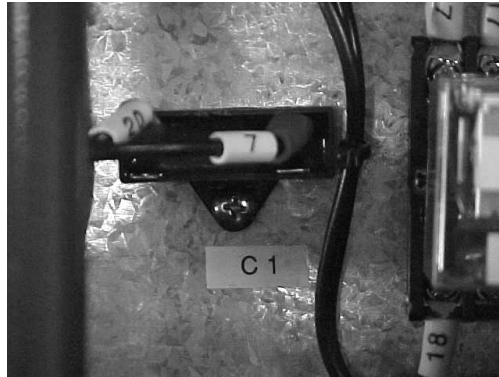

7. Make sure wires number 20 and 7 are connected to C1 capacitor.



8. Make sure RL1, 220V relay is secure in relay socket and points are not burnt.

SS-1622MK Sealer Service Manual

MAGNETIC HOLD DOWN



6. Seal head will not stay down – sealer operates normally otherwise.

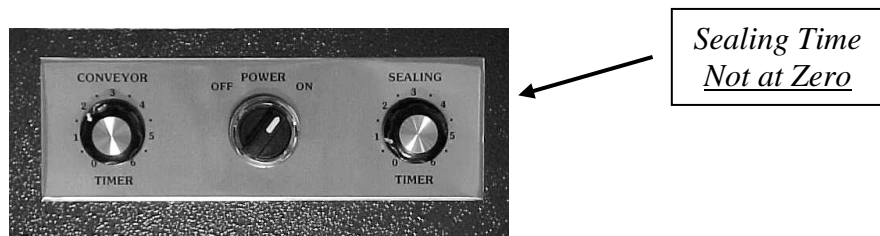

7. Check seal timer (TR2) setting. Make sure it is not set at zero. Also, check to see if burned or damaged.

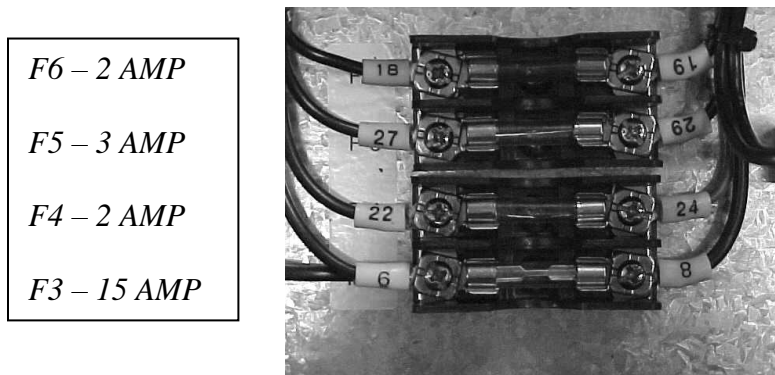

- F6 – 2 AMP
- F5 – 3 AMP
- F4 – 2 AMP
- F3 – 15 AMP

8. Check fuse F5, 3AMP, wire 27 and 29.

SS-1622MK Sealer Service Manual

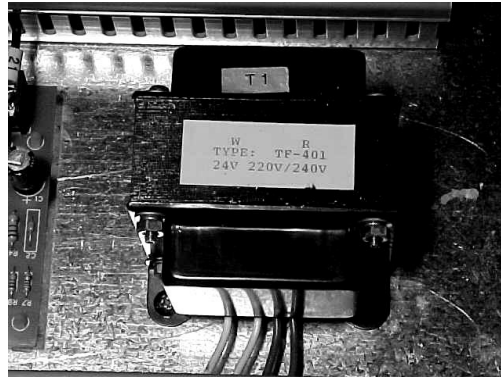

9. Check for 220 Volts (nominal) to primary of transformer (T1).
10. If voltage is present to primary winding of transformer (T1), check for 24 (nominal) volts output from secondary of transformer.

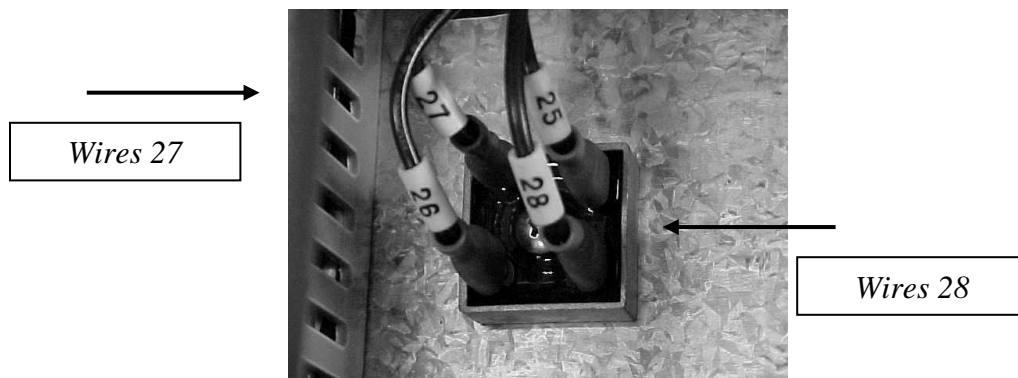

11. Check for 24 (nominal) volts DC output from + (positive) and – (negative) wires number 27 and 28 on terminals of rectifier. If no DC voltage, replace rectifier.

SS-1622MK Sealer Service Manual

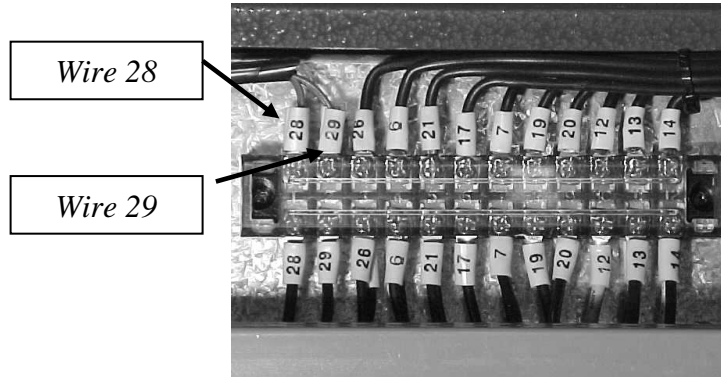

7. Check for circuit continuity through windings of hold-down magnets. **Check on terminal strip wires 28 and 29. Disconnect from terminal strip before testing.**

SS-1622MK Sealer Service Manual

EXCESSIVE FILM DRAG

1. Check for proper film threading. (See diagram on page 23.)

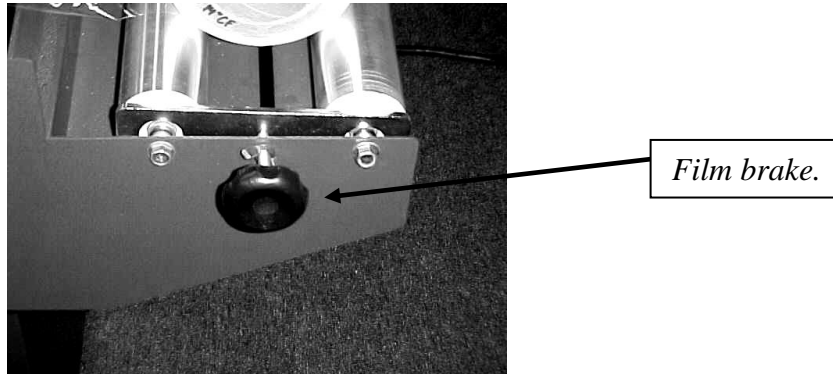

2. Loosen film roll brake.

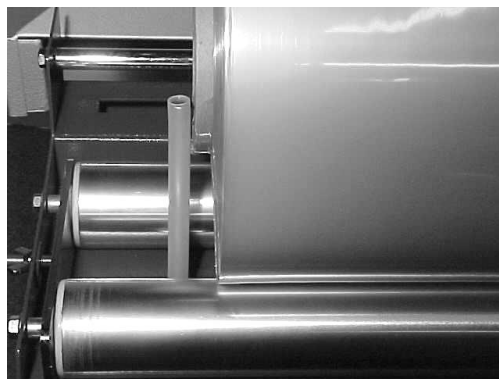

3. Make sure film guide rolls are not restraining roll from turning freely.

SS-1622MK Sealer Service Manual

EXCESSIVE FILM WINDING OR "SPILL"

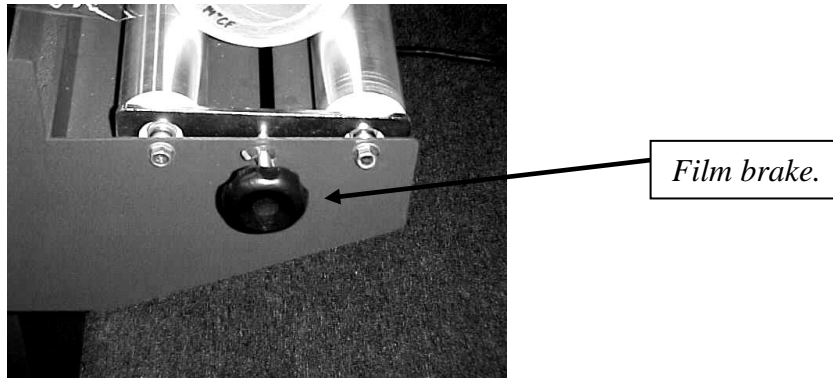

1. Tighten film roll brake.

SS-1622MK Sealer Service Manual

MAINTENANCE**MICRO KNIFE BAND RIBBON COMPENSATOR ADJUSTMENT**

Adjustment of the band ribbon compensator may be required under the following conditions:

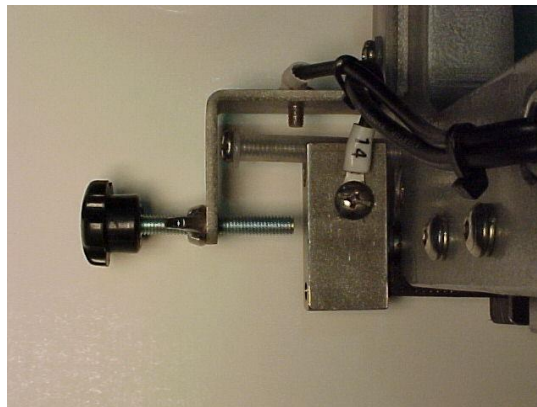

1. During continuous use. After about 15 minutes of sealer operation, check seal quality and, if required, reset compensator. This may be necessary as a result of heat buildup in the sealing head, or stretching of band ribbon.
2. After installing new Band Ribbon, make sure the Band Ribbon lies properly over the entire length of the seal bar in the channel.
3. If charring of film is noted, there is too much heat.
4. If sealing is incomplete, there is not enough heat.

To adjust the band ribbon compensator, refer to the adjustment instructions on the following pages:

SS-1622MK Sealer Service Manual

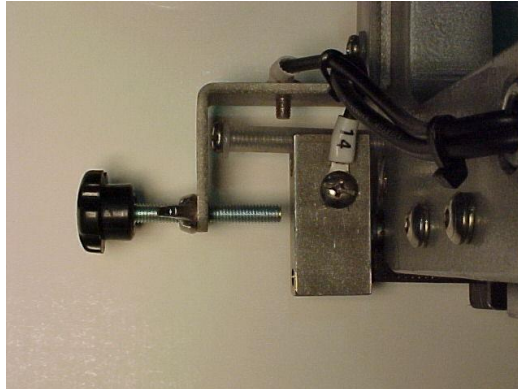
All Films Except Polyethylene

Adjust the band ribbon compensator (located at the left end of the front seal bar) by loosening the wing nut and turning the knurled-head screw until a $\frac{1}{4}$ " air gap exists. With folded film (i.e. two layers of film) in the sealing position, bring down the sealing head. Set the seal timer for a $\frac{1}{2}$ to 2 setting then examine the seal. Experimentally, in small increments, increase the band ribbon compensator air gap setting until a setting is obtained which yields a satisfactory seal and film cut off. It is important to remember that the smallest air gap at which a satisfactory seal and film cut off is obtained is the correct setting. If using PVC film we recommend using silicone bottom seal sponge.

SS-1622MK Sealer Service Manual

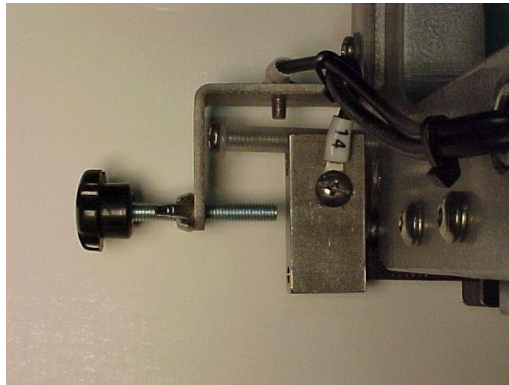
Polyethylene Films

On the band ribbon compensator, loosen the wing nut and turn the knurled-head screw until a $\frac{1}{4}$ " air gap exists. Tighten the wing nut. With folded film (e.g., two layers of film) in the sealing position, bring down the sealing head. Set the seal timer to position 1 or 2 on the timer dial setting.

Ordinarily, it will not be possible to obtain a satisfactory seal with the $\frac{1}{4}$ " gap setting. Experimentally, in small increments, increase the band ribbon compensator air gap setting until a setting is obtained which yields a satisfactory seal and film cut off.

SS-1622MK Sealer Service Manual

BAND RIBBON REPLACEMENT

The band ribbon is subject to constant wear and will require replacement as Teflon coating eventually wears off. To replace band ribbon, proceed as described below.

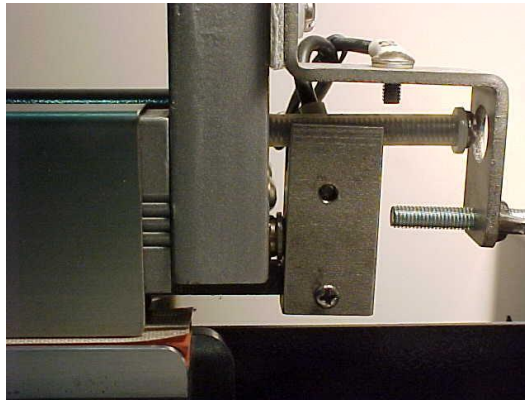
Replacing Micro Knife Band Ribbon

1. Loosen Allen screw on backside of compensator to loosen band ribbon.



2. Using a 2mm Allen wrench, loosen corner screw.

SS-1622MK Sealer Service Manual

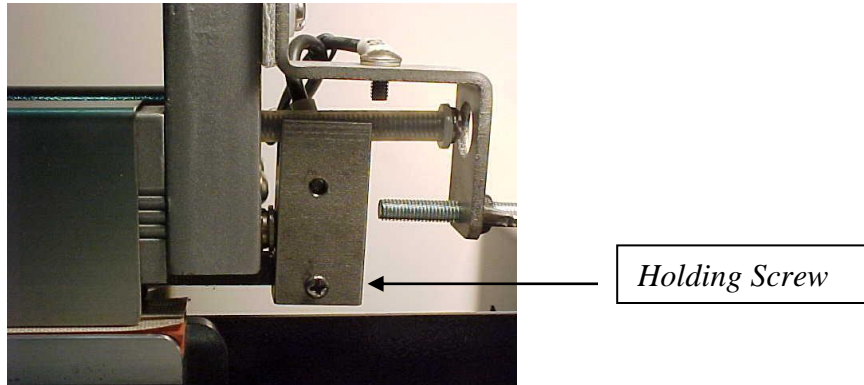

3. **Loosen screw** holding Band Ribbon in place on front seal bar.

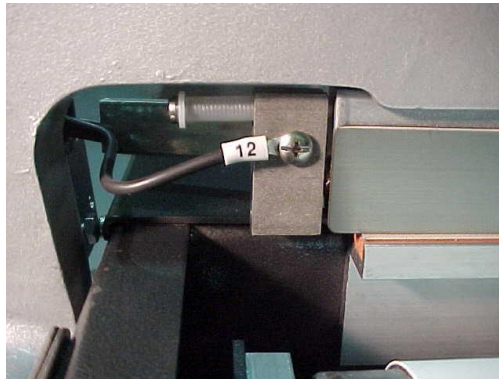

4. Loosen screw on back side of "side" seal bar compensator.

SS-1622MK Sealer Service Manual

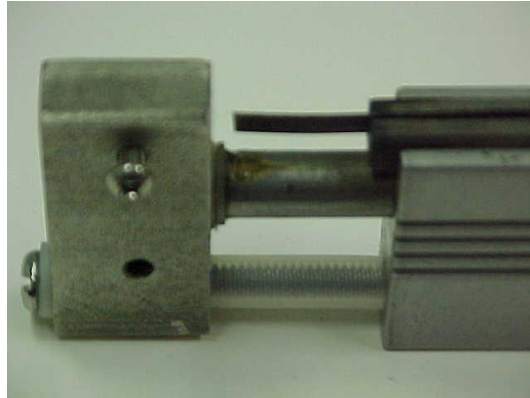

Note: Once screw is loosened spring loaded compensator will expand.



5. Remove old micro knife.

SS-1622MK Sealer Service Manual

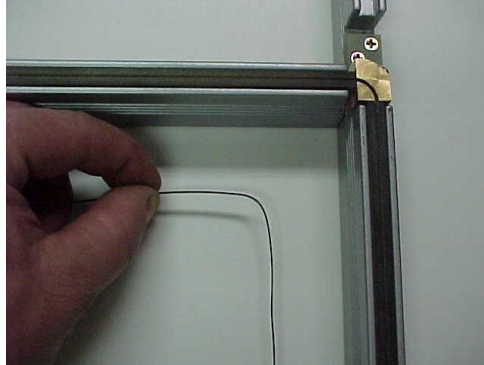

6. Take new micro knife band ribbon and bend corner approximately 90 degrees.

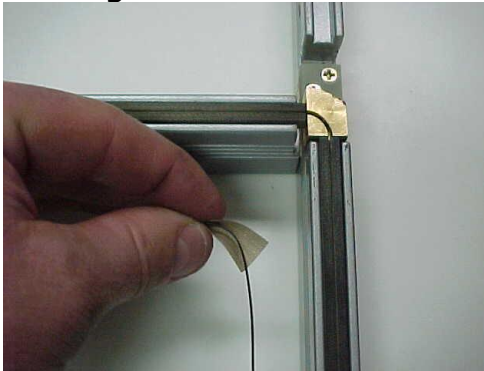

7. Cut a piece of 3 mill Teflon tape and wrap around band ribbon before inserting into corner-block of seal bar.



8. Push band ribbon into corner block until it is fully seated at bottom of channel. Cut off excess Teflon tape to insure good corner seal.

SS-1622MK Sealer Service Manual

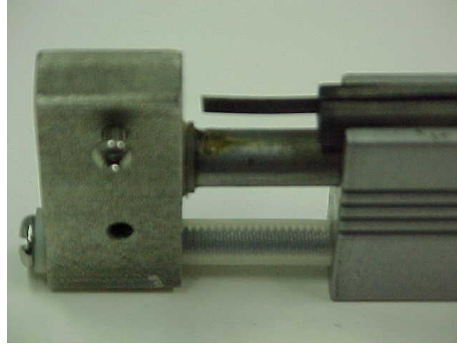

9. Insert band ribbon into remaining length of channel.

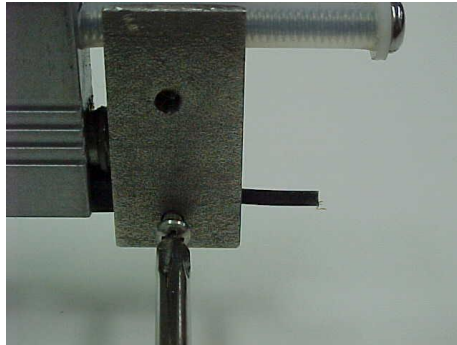

12. Push spring loaded compensator forward and tighten lock screw.

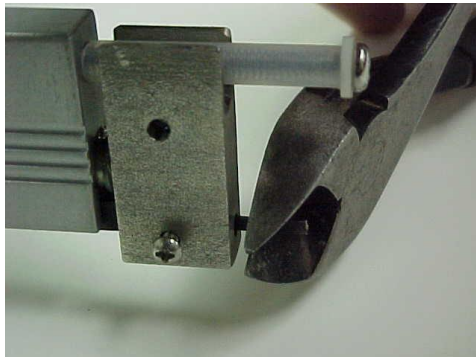

13. Cut off excess length of band ribbon.

SS-1622MK Sealer Service Manual

Important: After replacing Band Ribbon, be sure to adjust the setting of the element compensator. See page 27 for instruction.

SS-1622MK Sealer Service Manual

TAPE REPLACEMENT

The item most subject to wear on the sealer is the Teflon tape used to cover the silicone sponge rubber on the sealing bar. This $\frac{3}{4}$ " x 10 mill Teflon tape should never be permitted to burn through.

To replace tape, proceed as follows:



1. Strip off old tape.
2. Cut off proper length of new Teflon, peel off backing, and press new tape into position.
3. Apply $\frac{1}{2}$ " x 10 mill Teflon tape over the top of the $\frac{3}{4}$ " Teflon tape.

SS-1622MK Sealer Service Manual

SILICONE RUBBER SEALING PAD REPLACEMENT

Occasionally it will be necessary to replace the silicone rubber sealing pads. This should be done if the following is noted:

- Gaps in the seal
- Weak seals
- Improper film cut-off
- Excessive sealing pressure required

To replace rubber, proceed as follows:

1. Seal pads are designed with a channel for easy replacement. Pull silicone rubber out of the channel.
2. Replace with new silicone rubber. Press rubber back into channel.
3. Install $\frac{3}{4}$ " – 10 mil Teflon tape on top of rubber.
4. Install $\frac{1}{2}$ " – 10 mil Teflon tape over the $\frac{3}{4}$ " tape.

SS-1622MK Sealer Service Manual

Sealing Pad Pressure Adjustment for Head Return Cylinder

Uniform pressure between the sealing elements and the sealing pads must always be maintained for proper sealing uniformity, and to prevent element hot-spots and premature burnout. This adjustment should be checked periodically and should always be checked when sealing gaps occur. Proceed as follows:

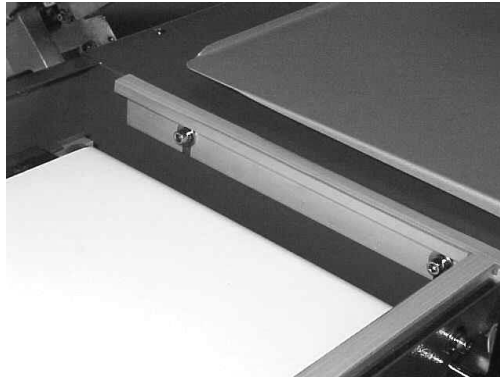

1. Loosen all five bolts on lower pads just enough to maintain a moderate sliding pressure.

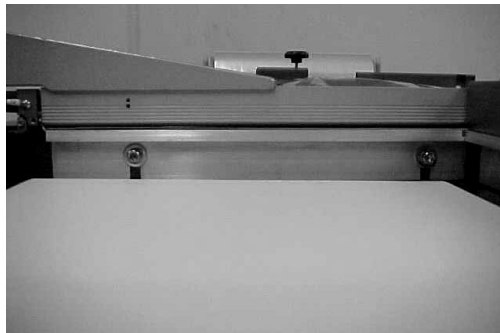

2. With sealing head resting on lower pads, make sure there are no air gaps, then tighten the five bolts on the lower pad.
3. Adjust magnets (see page 59 for magnet adjustment).

SS-1622MK Sealer Service Manual

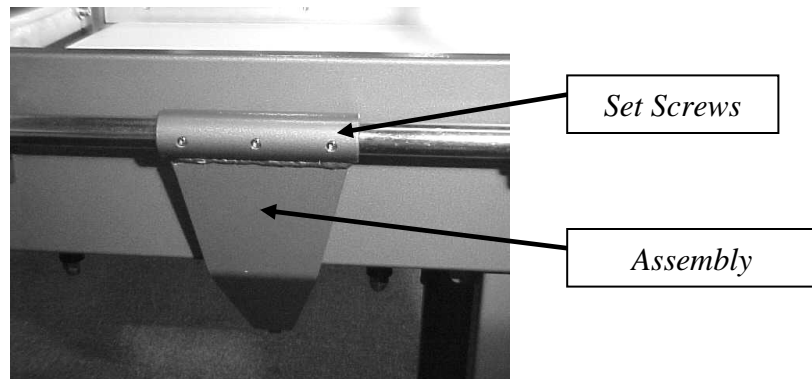
Adjust Height of Seal Bar

4. To raise or lower seal bar height, adjust seal head cylinder assembly casting by loosening the three set screws on shaft. Move assembly casting forward or backward, then reset seal head by locking set screws.



5. Cycling head up and down, adjust set screw for proper head speed and cushion.

SS-1622MK Sealer Service Manual

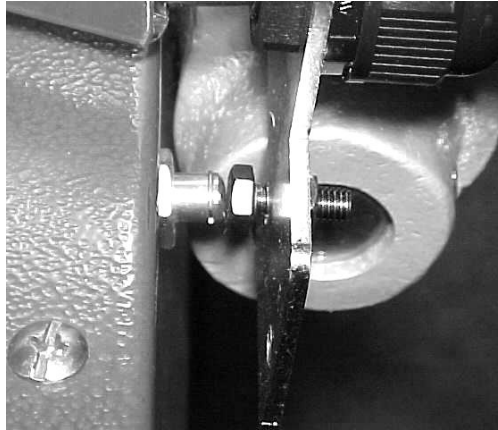
Band Ribbon Pulse Switch Adjustment

The sealing cycle should not begin until the sealing head is within $\frac{1}{4}$ " or less of the film to be sealed. If the magnets energize before the head is within $\frac{1}{4}$ " of the film, loosen the lock-nut and turn the screw (located at the rear end of the side seal bar) up slightly (counterclockwise when viewed from above). The correct adjustment has been obtained when the magnets energize just as the seal bar comes into contact with lower pads.

SS-1622MK Sealer Service Manual

Adjustment of Magnets for Correct Sealing Pressure

All magnets have been factory adjusted for equal sealing pressure throughout the length of both the front and side seal bars. However, if an adjustment is required, proceed as follows:

1. Disconnect the sealer's power source.

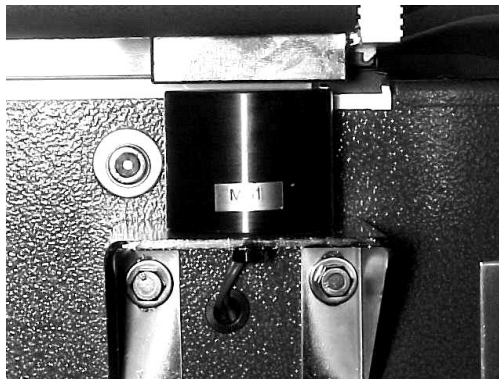

2. Loosen the lower magnet bolts on all lower magnets so that the magnets settle to their lowest position in the mounting slots.
3. Lower the sealer's operating handle fully and lift lower magnets to within 1/16" from the holders. Tighten the mounting bolts securely to retain the proper adjustment.

SS-1622MK Sealer Service Manual

Conveyor

From time to time, it will be necessary to disassemble the conveyor as it will need adjustments or replacement of worn parts and general maintenance. The following information is given to assist the operator in that general fashion. If the problem does not rectify itself with this general explanation, discuss it with an authorized distributor of Sealer Sales or with Sealer Sales directly.

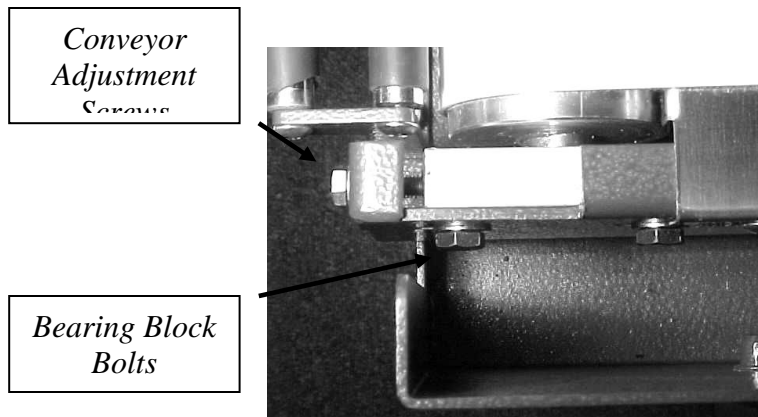

14. Adjust Discharge Conveyor Belt by loosening the Bearing Block Mounting Bolts, then adjust the Conveyor Adjustment Screw in to loosen belt, or out to tighten belt.

SS-1622MK Sealer Service Manual

Replacing Conveyor Motor

1. Disconnect power plug from source of power.

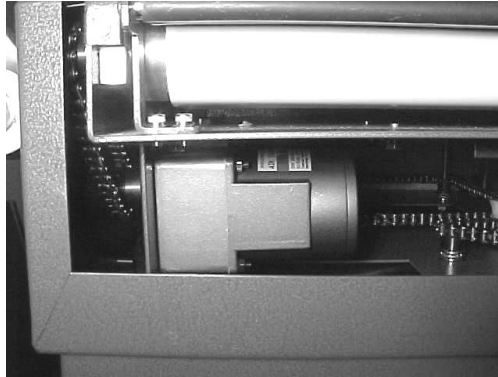

2. Disconnect the three power wires from the rear of the motor.
3. Loosen the four bolts that hold the motor mount bracket to the conveyor and slide motor mount forward.
4. Loosen set screws on sprocket that are attached to the motor and remove sprocket.
5. Remove four bolts. These bolts hold the motor in place. Hold motor while removing these bolts so the motor does not drop.
6. Follow steps 2-5 above in the opposite order to reinstall new motor against the conveyor frame and tighten set screws.

SS-1622MK Sealer Service Manual

Replacing Front and Side Seal Bars

1. Turn power switch to off position.

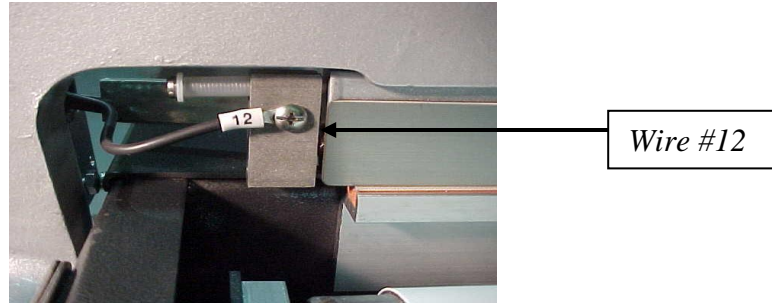

2. Remove wire #12 from side bar compensator.

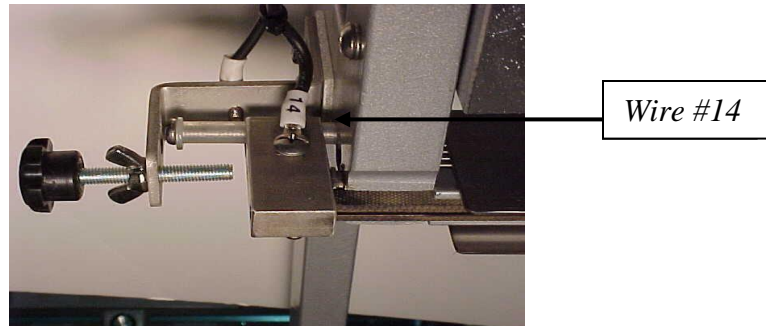

3. Remove wire #14 from front bar compensator.

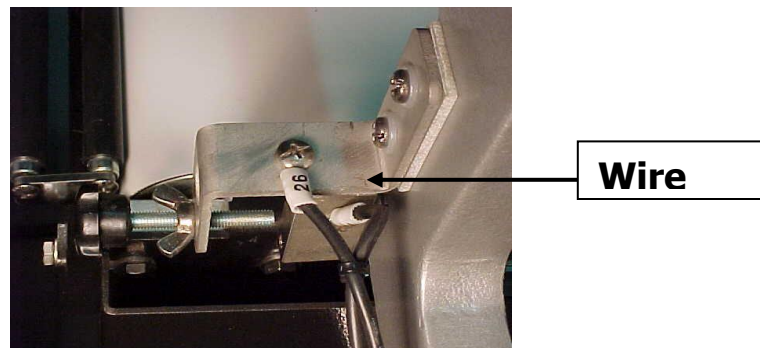

4. Remove wire #26 from temperature control bracket.

SS-1622MK Sealer Service Manual

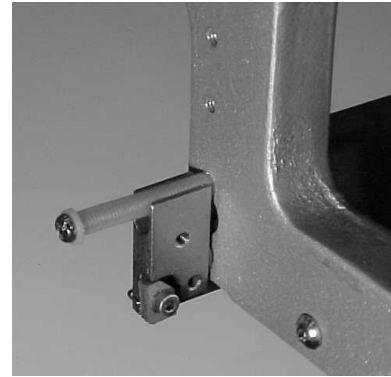

5. Remove temperature control bracket.
NOTE: Bracket is held in place with two screws. Also, **do not** lose the insulators.

6. Compress front bar compensator all the way in using your thumb and hold. Loosen Allen screw on compensator holding Band Ribbon.
Warning: Remove compensator slowly, applying tension, as compensator is spring loaded.

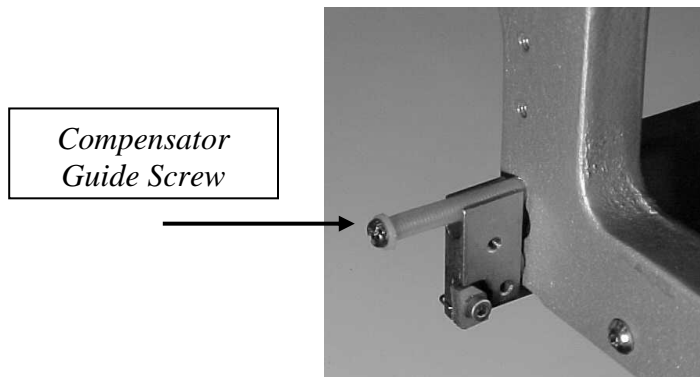

7. Remove compensator guide screw.

SS-1622MK Sealer Service Manual

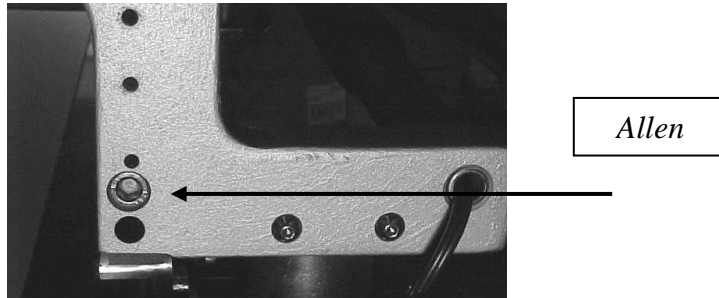

- 8. Remove Allen Bolt holding front seal bar to the outfeed bar.

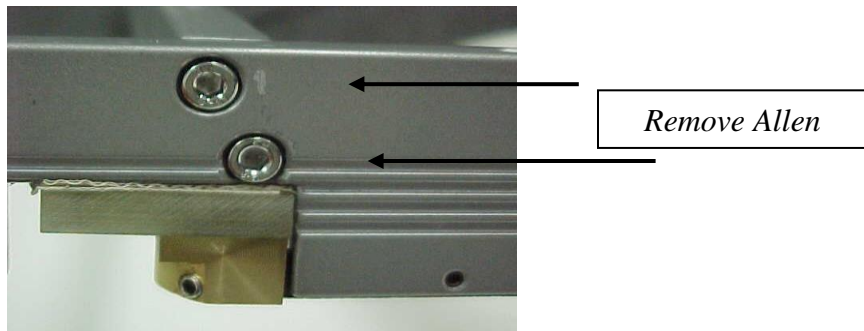

- 9. Remove bolts holding side seal bars to casting.
- 10. Remove seal head from entrance casting and outfeed bar.

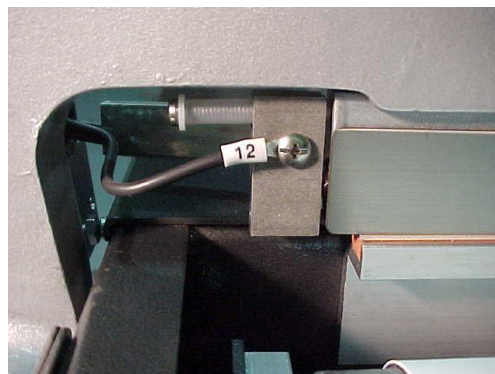

- 11. Remove the side bar compensator following steps 6 and 7.

SS-1622MK Sealer Service Manual



12. Remove upper magnet holder on side bar.
13. Remove handle.

SS-1622MK Sealer Service Manual

INSTALLATION OF TRANSITE CHANNELS

Front and Side Seal Bar

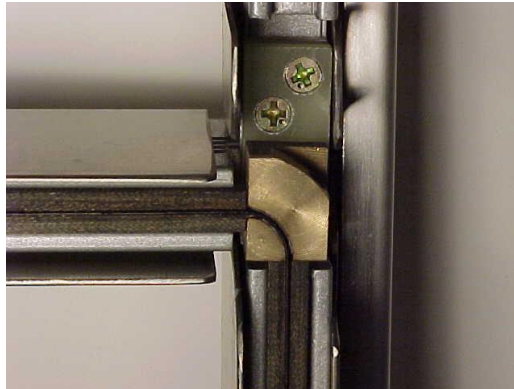

15. Install corner block.

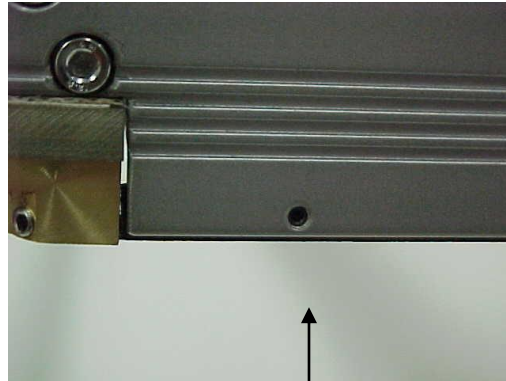

Channel Holding Screw

16. Remove the Allen screws holding channels in seal bar.

SS-1622MK Sealer Service Manual

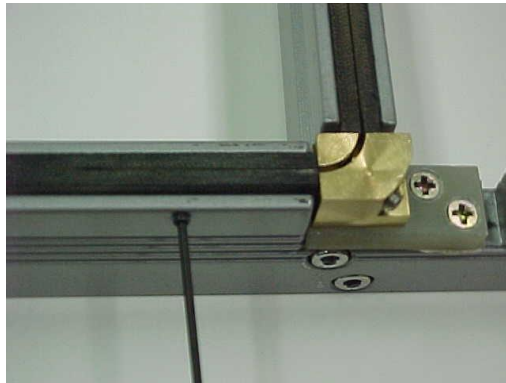

17. Remove Allen screw.



4. Remove transite channel and replace.

SS-1622MK Sealer Service Manual

Installation of Band Ribbon Compensators and Temperature Control Bracket

1. Lightly grease two compensator springs and put on each seal bar.

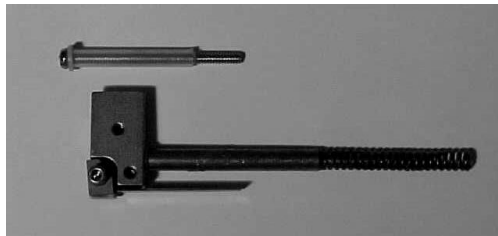

2. Insert compensator and compress in all the way.

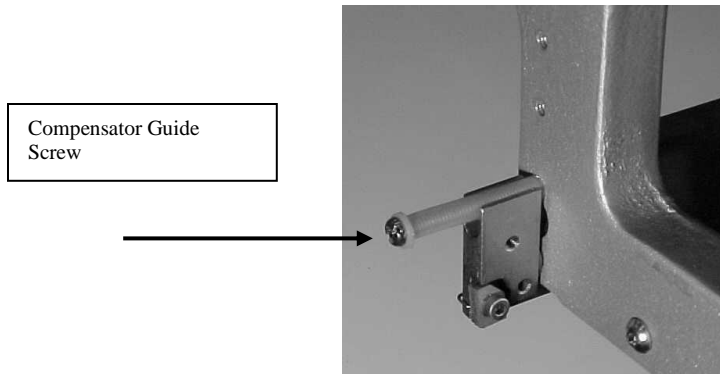

3. Install compensator guide screw assemblies.

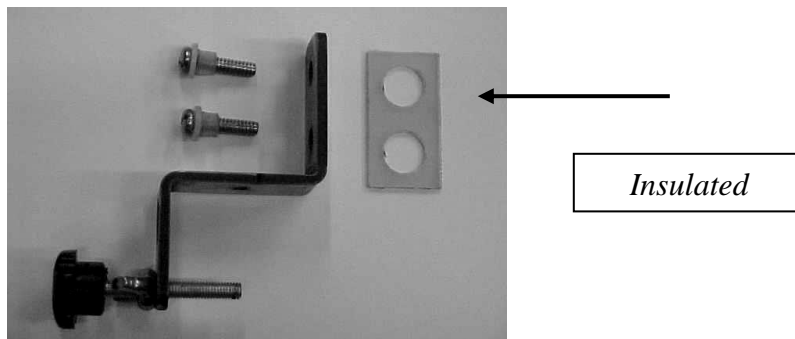

SS-1622MK Sealer Service Manual

4. On the front bar, install the temperature adjustment bracket.
Important: The temperature adjusting bracket must be insulated from the casting to work properly.
5. Install new band ribbon and reset temperature adjustment screw assembly.
6. Reconnect wires to seal head assembly.
 - (a) On the side seal bar, connect wire #12 to compensator block.

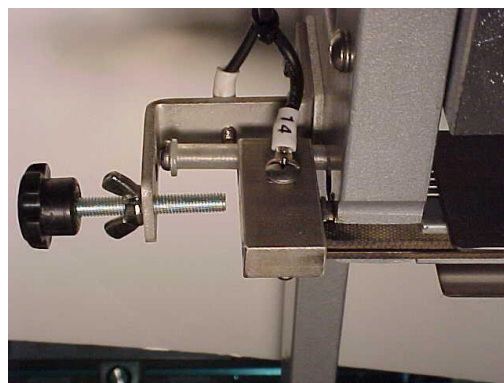
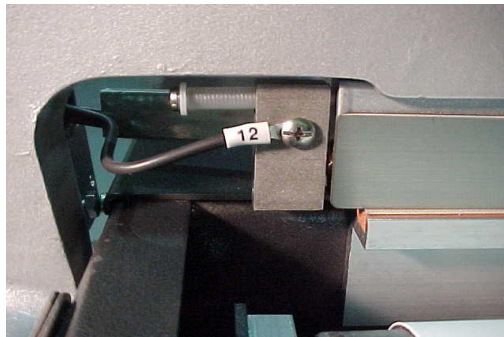

- (b) On the front bar, connect wire #14 to the compensator block.

SS-1622MK Sealer Service Manual



(c) On the temperature adjusting bracket wire #26.

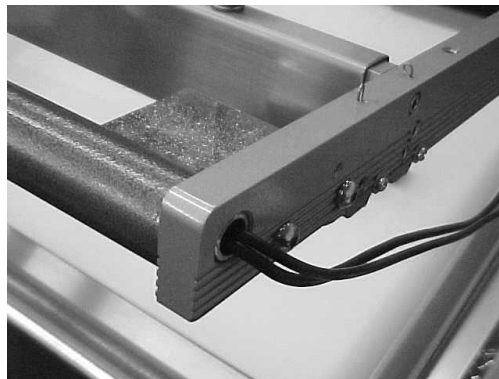

7. Install upper magnet holder on side bar.
8. Install handle and tighten set screws on each end.
9. **Double check all work done before starting the machine.**

SS-1622MK Sealer Service Manual

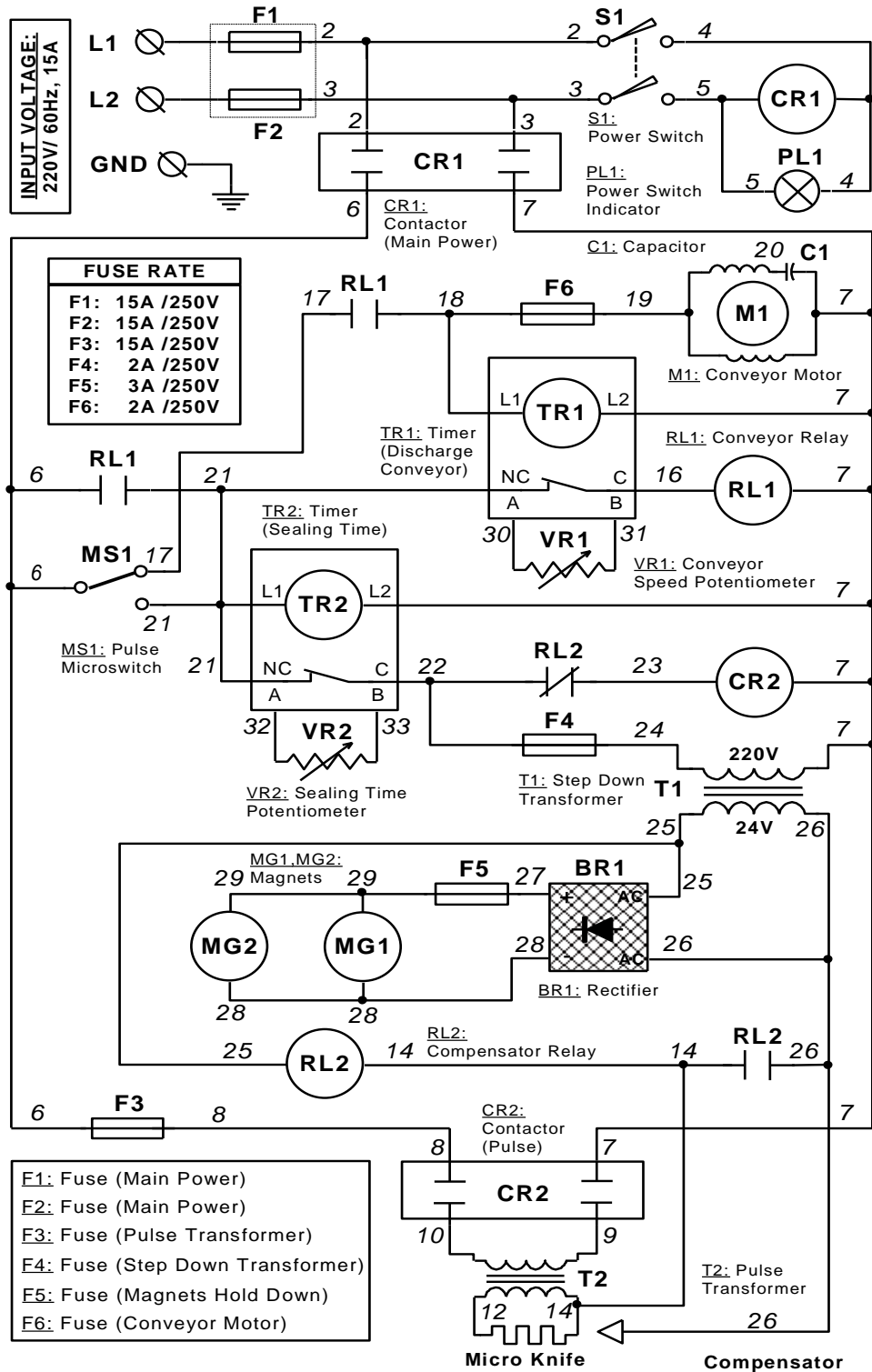

L-TYPE SEALER MODEL: PP1622MK (220V)

SS-1622MK Sealer Service Manual

**ELECTRICAL PANEL
DIAGRAM Controls for
SS-1622MK**

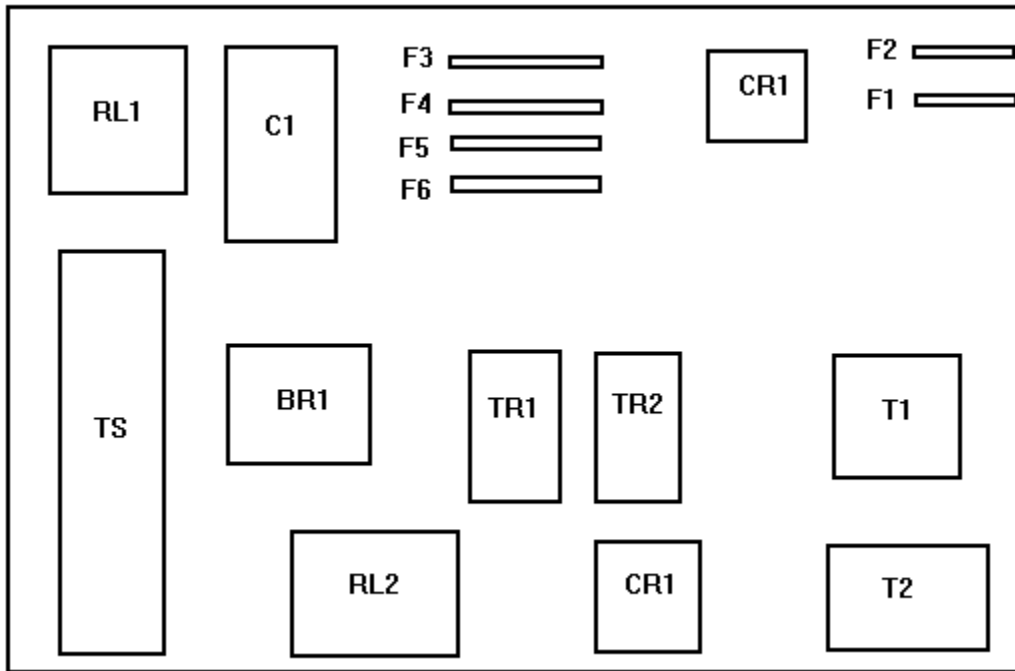

SS-1622MK Sealer Service Manual

MODEL SS-1622MK SEALER

Item	Part #	Qty	Parts List Nomenclature
S1	3400-45	1	Power On/off Switch
C1	3500-02	1	Capacitor – 3 MF 400 VAC
CR1	3400-13	1	Contactora Main Power
T1	1524-27	1	Stepdown Transformer – 220 Volt/24 Volt
M1	3400-16	1	Conveyor Motor
TR1	3400-76	1	Timer – Conveyor
CR2	3400-12	1	Contactora Pulse – 220 Volt
LS	3400-47	1	Pulse Limit Switch
BR1	1720-19	1	Rectifier
MAG 1 & 2	3400-76	2	Magnets Hold Down
TR2	3400-76	1	Timer – Sealing
RL1	3400-57	1	Conveyor Relay – 220 Volt
RL2	3400-56	1	Compensator Relay – 24 Volt
T2	3400-55	1	Pulse Transformer – 220 Volt
F1, F2, F3	3400-28	2	Fuse – 15 AMP 250 Volt
F5	3400-86	1	Fuse – 3 AMP 250 Volt
F4 & F6	3400-27	1	Fuse – 2 AMP 250 Volt
VR1, VR2	3400-68	1	Potentiometer

SS-1622MK Sealer Service Manual

1622MK SEALER REPLACEMENT PARTS

Part #	Qty	Description
3400-01	1	Arm Casting – Long
3400-02	1	Arm Casting – Short
3440-72	1	Band Ribbon
3400-96	2	Bearing – Discharge Conveyor
3440-10	4	Bearing – Discharge Conveyor Stabilizer
3440-40	1	Belt – Discharge Conveyor
3440-41	2	Bolts – Short Arm Casting Mounting
3400-95	1	Bracket – Actuator
3440-01	1	Bracket – Arm Return Cylinder
3440-68	1	Bracket – Seal Head Adjustment
3440-42	2	Bracket – Transition Roller Mounting
1720-19	1	Bridge Rectifier
3500-02	1	Capacitor – 3 MF 400 VAC
3400-03	4	Casters
3400-04	2	Chain Master Link
3400-05	1.5	Chain – Riveted (per ft.) Conveyor Motor
3440-43	1	Chain – Riveted (4 ft) -- Discharge Conveyor Adjustment
1521-49	1	Compensator Block Insulator – Fiber Washer
3440-81	2	Compensator Block – Stainless Steel
3440-44	1	Compensator Screw
3440-75	1	Compensator Shaft – Front
3440-76	1	Compensator Shaft – Side
3440-77	1	Compensator Shaft Spring
3400-09	1	Conduit (per ft.)
3400-11	1	Conduit Connector – Straight – 1/2"
3400-12	2	Contacto – 3 pole – 35 AMP
3400-14	1	Conveyor Adjusting Bracket
3440-66	1	Corner Block
3440-02	1	Cylinder – Head Return
3440-47	4	Discharge Conveyor – 8" Threaded Adjustment Bolts
3440-86	1	Discharge Conveyor – Nylon Take-up Block

SS-1622MK Sealer Service Manual

Part #	Qty	Description
3400-18	1	Drive Shaft
3400-19	1	Film Clamp – Side Stainless Steel
3400-20	1	Film Clamp – Front Stainless Steel
3440-48	2	Film Rack Guide Bolts
3400-21	1	Film Rack with Rollers – Complete
3440-49	2	Film Rack Roller – Shaft
3400-22	4	Film Rack Roller Bearings – Large
3400-23	4	Film Rack Bolts – 7mm x 1"
3400-24	2	Film Rack Roller
3400-25	2	Film Rack Guide Bolt Sleeve
3400-26	1	Film Rack Guide Knob
3440-50	1	Film Unwind Tension Plate
3440-51	1	Film Unwind Tension Adjust Knob
3400-27	1	Fuse – 2 AMP – Conveyor
3400-28	1	Fuse – 15 AMP
3400-30	1	Fuse 3 AMP
3400-31	1	Fuse Holder
3440-03	1	Guard – Discharge Conveyor Motor
3440-52	1	Handle – Front Seal Bar
3400-32	1	Handle – Crank for Conveyor
3400-34	1	Idler Roller Assembly
3440-69	2	Insulation Sleeve
3400-35	2	Knob for Potentiometer
3440-37	1	Knob for Conveyor Crank Handle
3400-40	2	Magnets
3440-53	4	Magnets– Lower Mounting Bolts
3400-41	2	Magnet – Upper
3400-43	2	Magnet Holder – Lower
3400-45	1	Main Power Switch
3400-46	1	Main Power Switch Plate
3440-54	1	Micro Switch Activation Bolt
3400-47	1	Micro Switch – Safety Override, Pulse, Conveyor
3440-55	1	Motor – Discharge Conveyor
3440-56	2	Mounting Bracket – Transition Rollers

SS-1622MK Sealer Service Manual

Part #	Qty	Description
3400-48	2	Pillow Block Bearing
3400-49	1	Pin Perforator Assembly Complete with Shaft
3440-04	1	Pin Perforator Base – Adjustment Knob
3400-36	1	Pin Perforator Safety Cover Adjustment Knob
3440-59	1	Pin Perforator Safety Cover
3400-51	1	Pin Perforator Shaft
3400-52	1	Pin Perforator Wheel – 5/8" I.D.
3440-11	1	Pin Perforator Base – Nylon
3400-54	1	Product Separator Tray
3400-56	1	Relay – Compensator – 24 Volt
3400-57	1	Relay – Conveyor – 220 Volt
3400-58	2	Relay Base
3440-60	2	Rollers – Transition
3440-05	1	Roller – Discharge Belt – Idler and Drive
3440-62	1	Screw-wing (Product Loading Tray)
3440-73	1	Seal Bar – Upper Front – Complete
3440-74	1	Seal Bar – Upper Side – Complete
3440-63	4	Seal Pad – Lower, Mounting Bolts
3400-60	1	Seal Pad – Lower – Front Mounting Bracket
3400-61	1	Seal Pad – Lower – Side Mounting Bracket
3440-06	2	Screw – Guide with Insulator
3450-16	1	Seal Pad Sponge Rubber – Side
3450-22	1	Seal Pad Sponge Rubber – Front
3400-33	1	Shaft – Seal Head
3440-07	4	Shoulder Bolt – Film Clamps
3400-68	2	Speed Potentiometer (Vr1 & Vr2)
3440-22	1	Sponge – Handle
3440-08	4	Spring – Film Clamp
3440-67	2	Spacer – Film Clamp
3400-69	1	Sprocket – Conveyor Drive Shaft
3400-71	1	Sprocket – Conveyor Motor
3400-72	4	Sprocket – Conveyor Adjustment Up/Down
1350-08	1	Teflon Tape – 1/2" x 10 yds x 10 Mill 16"
1350-14	1	Teflon Tape – 3/4" x 10 yds x 10 Mill 16"

SS-1622MK Sealer Service Manual

Part #	Qty	Description
3440-64	1	Teflon Tape – 1/2" x 10 yds x 10 Mill 22"
3440-65	1	Teflon Tape – 3/4" x 10 yds x 10 Mill 22"
3400-73	1	Temperature Adjusting Bracket
1521-09	1	Temperature Adjustment Screw Assembly
3400-74	1	Terminal Strip – 12 Lug
3400-76	1	Timer – Conveyor
3400-76	1	Timer – Seal
1524-27	1	Transformer – Stepdown 200 Volt to 24 Volt T1
3400-85	1	Transformer – Pulse 220 Volt T2
3440-70	1	Transite Channel – Front
3340-71	1	Transite Channel – Side
3440-09	4	Washer Stainless Steel – Film Clamp
3440-90	1	Seal Head Assembly Complete-Front and Side

SS-1622MK Sealer Service Manual

Spare Parts List-SS-1622MK

Item #	Part #	Description	Qty.	Price
1	3500-14	Fuse Kit	1	
2		Fuse – 2 Amp Glass	2	
3		Fuse – 3 AMP Glass	2	
4		Fuse – 15 AMP Glass	2	
5		Fuse – 15 Amp- Solid	2	
6	1350-08	½" x 10 mill x 10 yd. Teflon tape	1 RL	
7	1350-14	¾" x 10 mill x 10 yd. Teflon tape	1 RL	
8	3450-1622	Seal Pad Rubber – Set	1	
9	3440-66	Corner Block	1	
10	3440-70/71	Transite Channel – Set	1	
11	3440-72	Band Ribbon	1	
Total Cost				\$Call